

## TEC226x-2 Series Programmable LONWORKS® Network Configurable Staged Thermostats

### Application Requirements

The TEC226x-2 Series Programmable LONWORKS® Network Configurable Staged Thermostats are specifically designed for single-stage and multi-stage control of heating/cooling equipment, such as rooftop and heat pump units.

Accurate temperature control is achieved with a time proportional control algorithm, which virtually eliminates the temperature offset associated with traditional, differential-based thermostats. For more advanced applications, economizer control logic has been integrated into the thermostat for use with proportional damper economizer actuators.

All programmable models contain a Single-Pole Single-Throw (SPST) auxiliary switch, which can be used to control lighting or disable the economizer function.

### Mechanical Installation

#### Location

Install the thermostat away from any heat source.

Do not install the thermostat:

- on an outside wall
- near an air discharge grill
- in a location affected by direct sun radiation
- in an area that restrains vertical air circulation to the thermostat

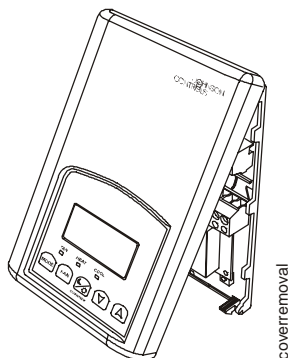
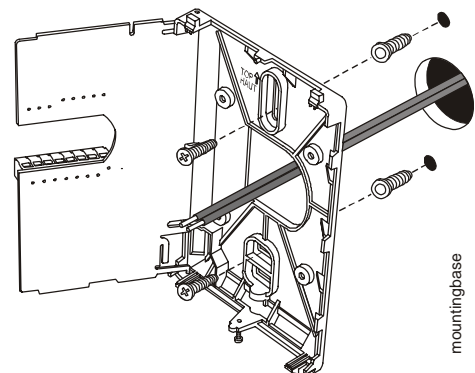

**Figure 1: Bottom of Thermostat**

To install the thermostat:

Wall surface must be flat and clean.

1. Remove the security screw on the bottom of the thermostat cover.
2. To open, pull on the bottom side of the thermostat (Figure 1).
3. Swing the thermostat circuit board to the left by pressing the pull tabs (Figure 2).
4. Pull cables 6" out of the wall.
5. Insert cable in the central hole of the base.
6. Align the base and mark the location of the two mounting holes on the wall. Install proper side of base up.



**Figure 2: Pull Tabs**

7. Install anchors in the wall.
8. Insert screws in mounting holes on each side of the base (Figure 2).
9. Gently swing the circuit board back on the base and push until the tabs lock it.
10. Pull out the screw terminal blocks using the pull tabs on each connector (Figure 3).
11. Strip each wire 1/4 inch.

12. Insert each wire according to wiring diagram.
13. Gently push excess wiring back into hole.
14. Install wiring terminals.
15. Reinstall the cover (top side first) and gently push extra wire back in the hole in the wall.
16. Install security screw.

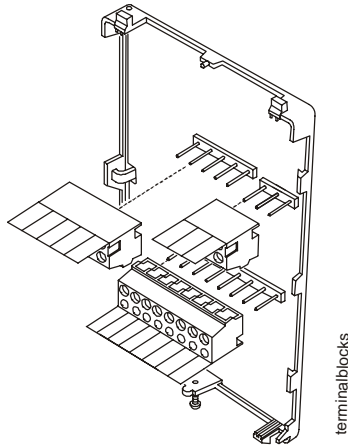

**Figure 3: Security Screw**

#### Caution

- If replacing an old thermostat, label the wires before removal of the old thermostat.
- Electronic controls are static sensitive devices. Discharge yourself properly before installing the thermostat.
- Short circuit or incorrect wiring may permanently damage the thermostat or the equipment.
- Anti-short cycling can be set to 0 minutes for equipment that possesses its own anti-cycling timer. Do not use that value unless the equipment is equipped with such internal timer. Failure to do so can damage the equipment.
- All thermostat devices are to be used only as operating controls. Whenever a control failure could lead to personal injury and/or loss of property, it becomes the responsibility of the user to add safety devices and/or an alarm system to protect against such catastrophic failures.

## Wiring

If the same power source is used for the heating stages, install jumper across RC and RH. Maximum current is 2.0 amperes.

If auxiliary output is used to toggle occupancy of the electronic control card inside the equipment, configure the relay parameter (Aux cont) to the Normally Open (N.O.) setting. A second relay can be added for additional functionality of the occupancy output.

Economizer output uses a half-bridge rectifier. Reference of the control signal is the common of the power supply of the thermostat, Terminal C.

Electromechanical contacts are to be used with the digital inputs. Electronic triacs cannot be used as a means of switching for the input. The switched leg to the input is Terminal C (common).

The transformer of the unit provides power to the thermostat and the additional loads that are wired to the thermostat.

## Electrical Installation

### Planning and Selecting Cables

Plan the placement of cables for inputs, outputs, communication, and power.

Place input, output, power, and network cables to avoid the effects of ambient noise.

Separate analog type cables for power, communication, inputs, and outputs from other types of cables.

### Connectors

The board connectors accept wires or flat cables: 22-12 AWG (0.14-2.5 mm<sup>2</sup>) per pole.

**Table 1: Cable Specifications**

Cable	Specification
Power	Minimum cable section 18 AWG
Inputs	Minimum cable section 20 AWG – twisted pair
Digital Outputs	Minimum cable section 18 AWG
Analog Outputs	Minimum cable section 20 AWG – twisted pair

## Wiring Analog Outputs

When configured as a digital type, the analog outputs can provide 60 mA of current for relay, or solid-state relay, operation.

**Table 2: Analog Output Characteristics**

Analog Output	Characteristic
<b>Voltage</b>	0 to 10 VDC when configured as an analog output 0 to 12 VDC when configured as a digital output
<b>Max Current</b>	60 mA @ 12 VDC when configured as digital (200 ohm load) 50 mA @ 10 VDC when configured as analog
<b>Protection</b>	Auto-reset fuse: 100 mA @ 68°F (20°C) 0 mA @ 140°F (60°C)

**Table 3: Thermostat Models**

Application	1 Heat/1 Cool	2 Heat/2 Cool	2 Heat/2 Cool and Economizer	Heat Pump
<b>Model (Programming with Scheduling)</b>	TEC2261-2	TEC2263-2	TEC2264-2	TEC2262-2

# Programmable Thermostat Wiring

## TEC2261-2 Single-Stage Thermostat

The TEC2261-2 features one fan, one heating stage, one cooling stage, and scheduling. Figure 4 shows a wiring example.

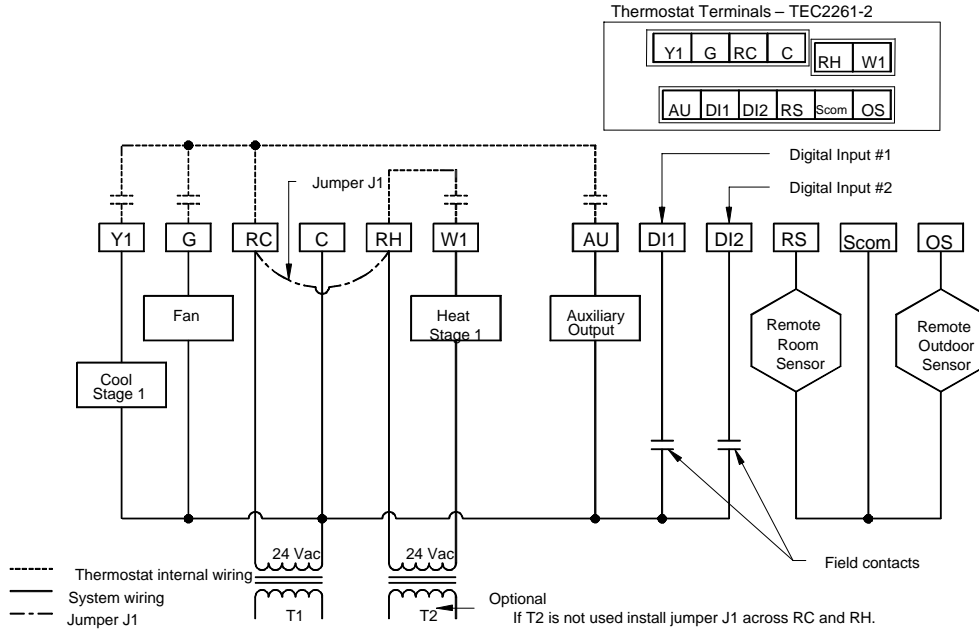

Figure 4: TEC2261-2 Single-Stage Thermostat

## TEC2263-2 Multi-Stage Thermostat

The TEC2263-2 features one fan, two heating stages, two cooling stages, and scheduling. Figure 5 shows a wiring example.

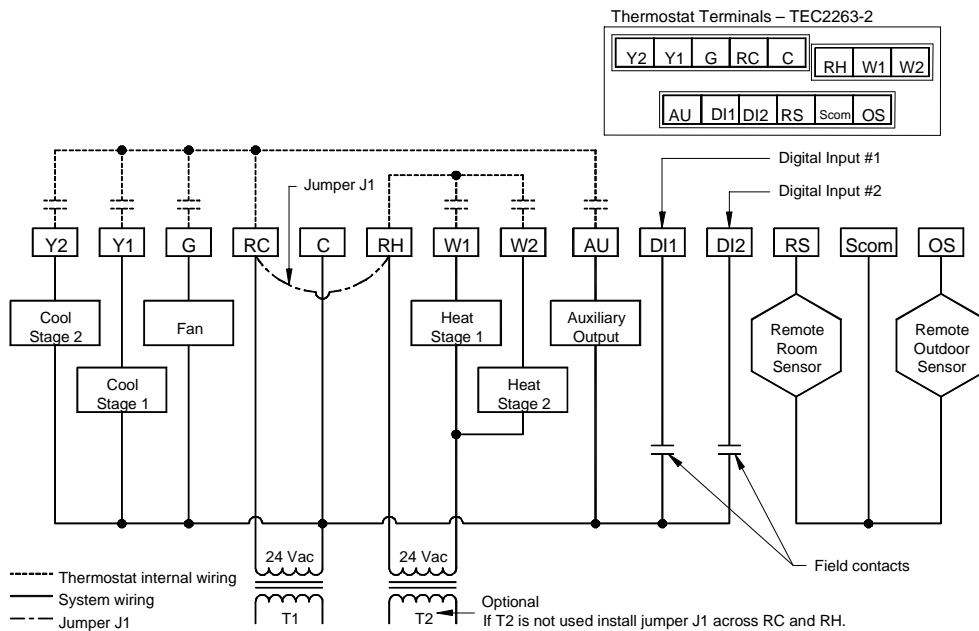

Figure 5: TEC2263-2 Multi-Stage Thermostat

### TEC2264-2 Economizer Thermostat

The TEC2264-2 features two heating stages, two cooling stages, an economizer, and scheduling. Figure 6 shows a wiring example.

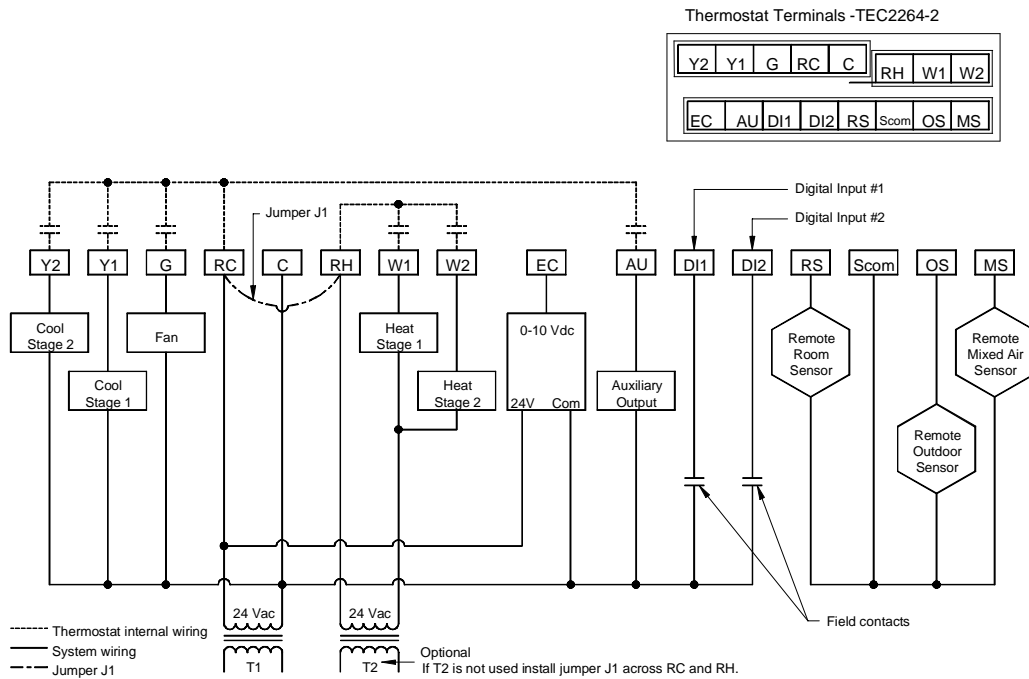

Figure 6: TEC2264-2 Economizer Thermostat

### TEC2262-2 Heat Pump Thermostat

The TEC2262-2 features one fan, three heating stages, two cooling stages, and scheduling. Figure 7 shows a wiring example.

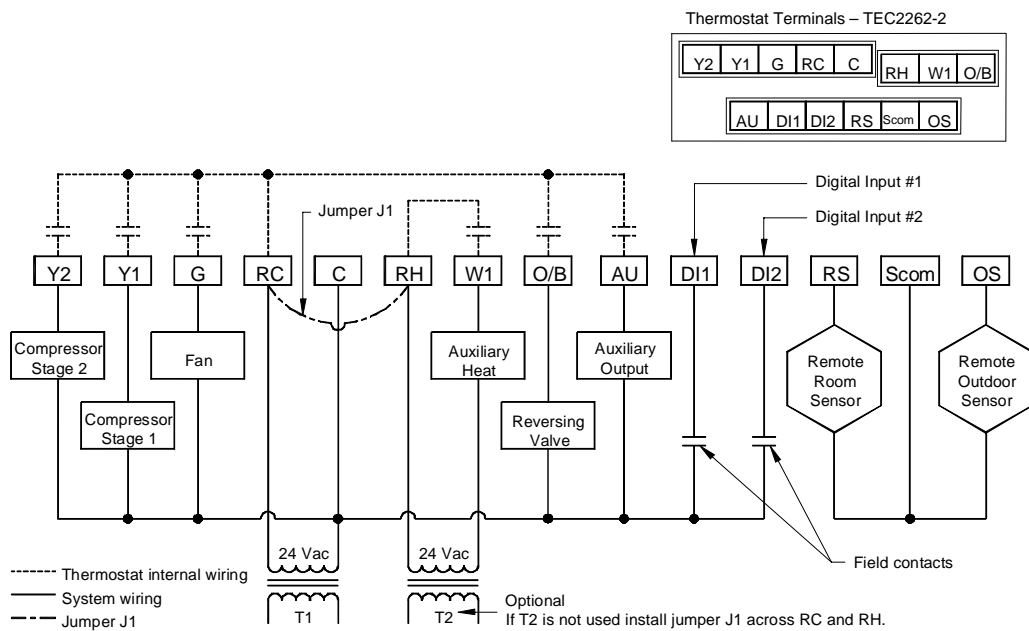

Figure 7: TEC2262-2 Heat Pump Thermostat

## Technical Specifications

<b>Product</b>	TEC226x-2 Series Programmable LONWORKS Network Configurable Staged Thermostats
<b>Agency Approvals</b>	FCC Class A - Class A computing device, Subpart J of Part 15 CULus UL873 File E234137 with CCN's XAPX (US) and XAPX7 (Canada)
<b>Power Requirements</b>	19-30 VAC 50 or 60 HZ; 2 VA (RC and C) Class 2
<b>Ambient Operating Conditions</b>	0 to 50°C (32 to 122°F); 0% to 95% RH
<b>Ambient Storage Conditions</b>	-30 to 50°C (-22 to 122°F); 0% to 95% RH
<b>Processor</b>	Neuron® 3120
<b>Communication</b>	LonTalk® Protocol
<b>Transceiver</b>	TP/FT-10; 78 Kbps
<b>Memory</b>	EEPROM
<b>Sensor</b>	Local 10 K NTC thermistor
<b>Resolution</b>	± 0.1°C (±0.2°F)
<b>Control Accuracy</b>	±0.5°C (±0.9°F) @21°C (70°F) typical calibrated
<b>Occupied and Unoccupied Setpoint Range Cooling</b>	12 to 37.5°C (54 to 100°F)
<b>Occupied and Unoccupied Setpoint Range Heating</b>	4.5 to 32°C (40 to 90°F)
<b>Room and Outdoor Air Temperature Range</b>	-40 to 50°C (-40 to 122°F)
<b>Proportional Band for Room Temperature Control</b>	Both outputs: 1.1°C (2.0°F)
<b>Digital Inputs</b>	Relay dry contact only across C Terminal to DI1 or DI2
<b>Contact Output Rating</b>	Each relay output: (Y1, Y2, G, W1, W2 and AU) 30 VAC, 1 A maximum/30 VAC, 3 A in-rush
<b>Economizer Analog Output Rating</b>	0 to 10 VDC into 2 K ohm resistance minimum
<b>Economizer Analog Output Accuracy</b>	±3% typical
<b>Wire Gauge</b>	18 gauge maximum, 22 gauge recommended
<b>Dimensions</b>	125 mm x 86 mm x 29 mm (4.94" x 3/38" x 1.13")
<b>Shipping Weight</b>	0.34 kg (0.75 lb)

*The performance specifications are nominal and conform to acceptable industry standards. For application at conditions beyond these specifications, consult the local Johnson Controls office. Johnson Controls, Inc. shall not be liable for damages resulting from misapplication or misuse of its products.*



**Controls Group**  
507 E. Michigan Street  
P.O. Box 423  
Milwaukee, WI 53201

Published in U.S.A.  
[www.johnsoncontrols.com](http://www.johnsoncontrols.com)