

TEC21x6(H)-2 Series N2 Networked Thermostats with Two Outputs and Three Speeds of Fan Control

Installation Instructions

Part No. 24-9890-218, Rev. A
Issued December 1, 2005
Supersedes October 25, 2005

Applications

The TEC21x6(H)-2 Series Thermostats are N2 networked devices that provide control of two- or four-pipe fan coils, cabinet unit heaters, or other equipment using on/off, floating, or proportional 0 to 10 VDC control input and three speeds of fan control. The technologically advanced TEC21x6(H)-2 Series Thermostats feature a Building Automation System (BAS) N2 Bus communication capability that enables remote monitoring and programmability for efficient space temperature control. Specific models are available to accommodate commercial and hospitality applications.

The TEC21x6(H)-2 Series Thermostats feature an intuitive user interface with backlit display that makes setup and operation quick and easy. The thermostats also employ a unique, proportional control algorithm that virtually eliminates temperature offset associated with traditional, differential-based thermostats.

IMPORTANT: The TEC21x6(H)-2 Series Thermostats are intended to provide an input to equipment under normal operating conditions. Where failure or malfunction of the thermostat could lead to personal injury or property damage to the controlled equipment or other property, additional precautions must be designed into the control system. Incorporate and maintain other devices such as supervisory or alarm systems or safety or limit controls intended to warn of, or protect against, failure or malfunction of the thermostat.

North American Emissions Compliance

United States

This equipment has been tested and found to comply with the limits for a Class A digital device pursuant to Part 15 of the FCC Rules. These limits are designed to provide reasonable protection against harmful interference when this equipment is operated in a commercial environment. This equipment generates, uses, and can radiate radio frequency energy and, if not installed and used in accordance with the instruction manual, may cause harmful interference to radio communications. Operation of this equipment in a residential area is likely to cause harmful interference, in which case the user will be required to correct the interference at his/her own expense.

Canada

This Class (A) digital apparatus meets all the requirements of the Canadian Interference-Causing Equipment Regulations.

Cet appareil numérique de la Classe (A) respecte toutes les exigences du Règlement sur le matériel brouilleur du Canada.

Installation

Location Considerations

Locate the TEC21x6(H)-2 Series Thermostat:

- on a partitioning wall, approximately 5 ft (1.5 m) above the floor in a location of average temperature
- away from direct sunlight, radiant heat, outside walls, behind doors, air discharge grills, stairwells, or outside doors
- away from steam or water pipes, warm air stacks, unconditioned areas (not heated or cooled), or sources of electrical interference

Note: Allow for vertical air circulation to the TEC21x6(H)-2 Series Thermostat.

To install the thermostat:

1. Use a Phillips-head screwdriver to remove the security screw on the bottom of the thermostat cover.
2. Pull the bottom edge of the thermostat cover and open the thermostat as illustrated in Figure 1.

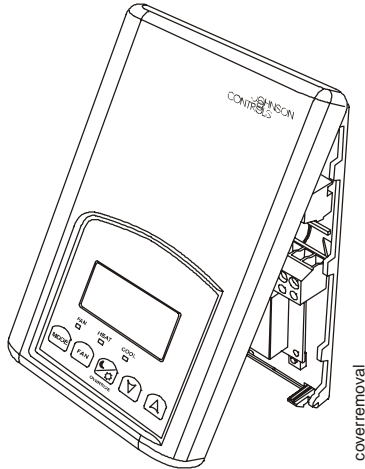

Figure 1: Removing the Thermostat Cover

3. Carefully pull the locking tabs on the right side of the thermostat mounting base and unlock the Printed Circuit Board (PCB). Open the PCB to the left as illustrated in Figure 2.

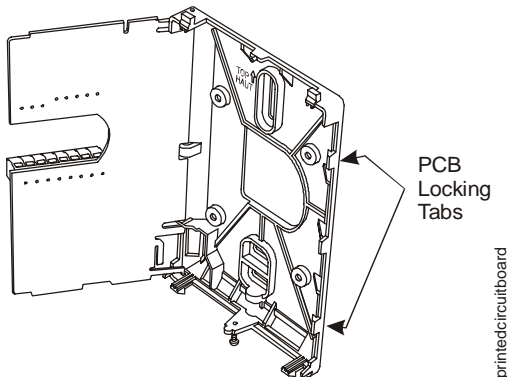

Figure 2: Opening the Thermostat PCB

4. Pull approximately 6 in. (152 mm) of wire from the wall and insert the wire through the hole in the thermostat mounting base.
5. Align the thermostat mounting base on the wall and use the base as a template to mark the two mounting hole locations.

Note: Be sure to position the thermostat mounting base so that the arrow on the base points upward to indicate the top of the thermostat.

6. Drill a 3/16 in. (5 mm) hole at each of the two marked locations and tap nylon anchors (included with the thermostat) flush to the wall surface.
7. Position the thermostat mounting base on the wall and use the two mounting screws (included with the thermostat) to secure the base to the surface as illustrated in Figure 3.

Note: Be careful not to overtighten the mounting screws.

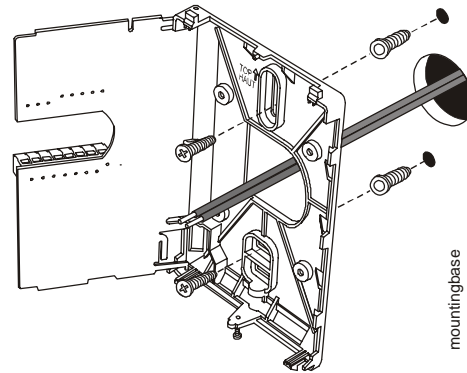

Figure 3: Securing the Thermostat Mounting Base to the Wall

8. Swing the PCB back to the right and carefully snap it into the locking tabs on the thermostat mounting base.
9. Pull the pull-tabs on each of the connectors and remove the screw terminal blocks as illustrated in Figure 4.

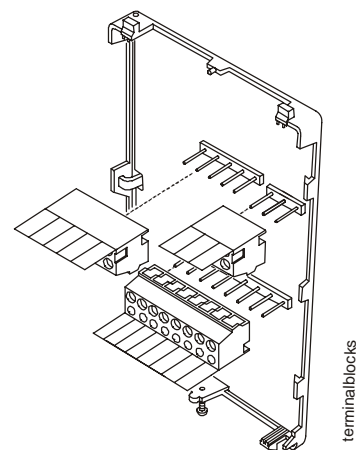

Figure 4: Removing the Screw Terminal Blocks

Wiring

When an existing thermostat is replaced, remove and label the wires to identify the terminal functions. When a TEC21x6(H)-2 Series Thermostat is replaced, simply remove the old screw terminal blocks and reinsert them onto the PCB of the replacement thermostat.



CAUTION: Risk of Electric Shock.
Disconnect the power supply before making electrical connections to avoid electric shock.



CAUTION: Risk of Property Damage.
Do not apply power to the system before checking all wiring connections. Short circuited or improperly connected wires may result in permanent damage to the equipment.

IMPORTANT: Make all wiring connections in accordance with local, national, and regional regulations. Do not exceed the electrical ratings of the TEC21x6(H)-2 Series Thermostat.

To wire the thermostat:

1. Strip the ends of each wire 1/4 in. (6 mm) and connect them to the appropriate screw terminals as indicated in Table 1 and Figure 5 through Figure 9.
2. Carefully push any excess wire back into the wall. Seal the hole in the wall with fireproof material to prevent drafts from affecting the ambient temperature readings.
3. Reinsert the screw terminal blocks onto the PCB.
4. Reattach the thermostat cover to the mounting base (top side first).
5. Use a Phillips-head screwdriver to reinstall the security screw on the bottom of the thermostat cover.

Table 1: Terminal Identification (See Figure 5.)

Terminal Number	Terminal Label			Function
	TEC2116(H)-2	TEC2126(H)-2	TEC2146(H)-2	
1	Fan-H	Fan-H	Fan-H	Fan On – High
2	Fan-M	Fan-M	Fan-M	Fan On – Medium
3	Fan-L	Fan-L	Fan-L	Fan On – Low
4	24 V~ Hot	24 V~ Hot	24 V~ Hot	24 VAC from Transformer
5	24 V~ Com	24 V~ Com	24 V~ Com	24 VAC (Common) from Transformer
6	BO5 Aux	BO5 Aux	BO5 Aux	Aux BO (Auxiliary Output)
7	BO5 Aux	BO5 Aux	BO5 Aux	Aux BO (Auxiliary Output)
8	BO3	BO3	Blank	Open Heat
9	Blank	BO4	AO2	Close Heat
10	Blank	BO1	AO1	Open Cool
11	BO2	BO2	Blank	Close Cool
12	BI1	BI1	BI1	Configurable Binary Input 1
13	RS	RS	RS	Remote Sensor
14	Scom	Scom	Scom	Sensor Common
15	BI2	BI2	BI2	Configurable Binary Input 2
16	UI3	UI3	UI3	Configurable Universal Input 3
Blank	N2+, N2-, REF	N2+, N2-, REF	N2+, N2-, REF	N2 Bus

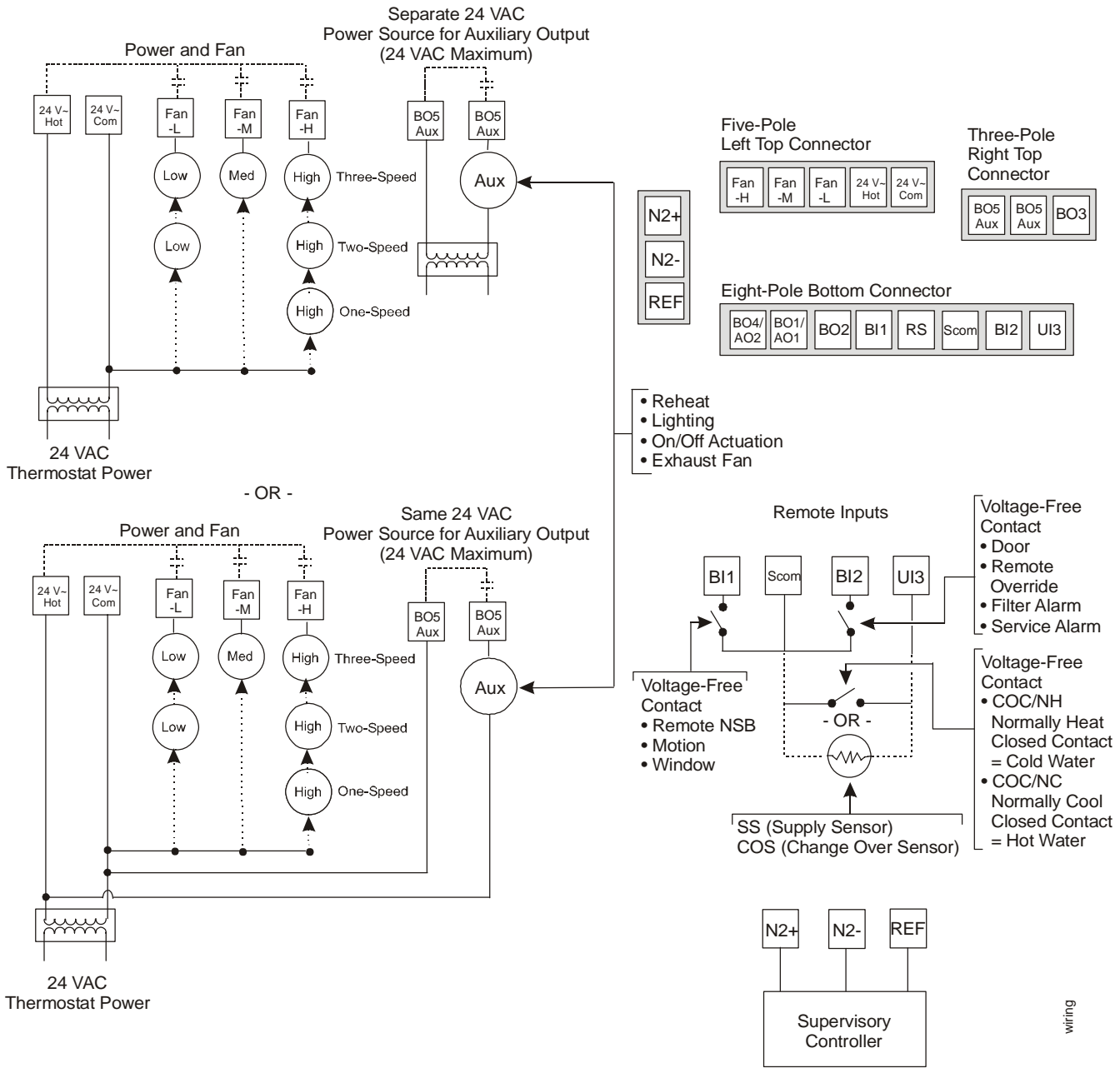

Figure 5: Wiring the TEC21x6(H)-2 Series Thermostat (See Table 1.)

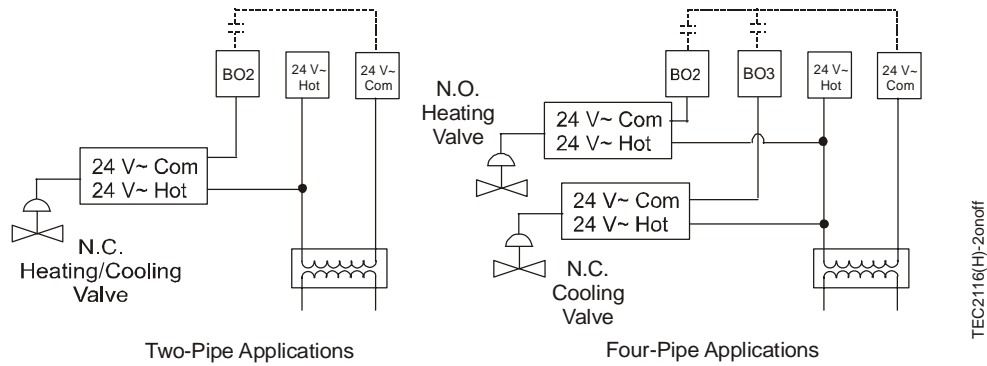

Figure 6: Wiring TEC2116(H)-2 Thermostats for On/Off Control

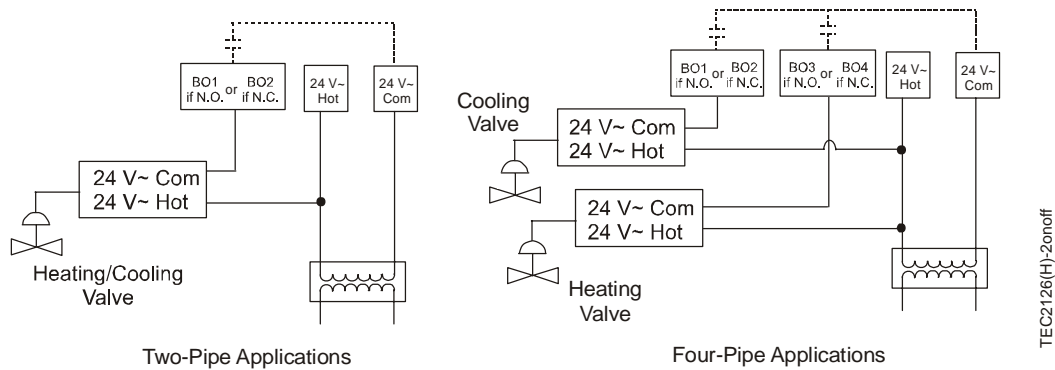

Figure 7: Wiring TEC2126(H)-2 Thermostats for On/Off Control

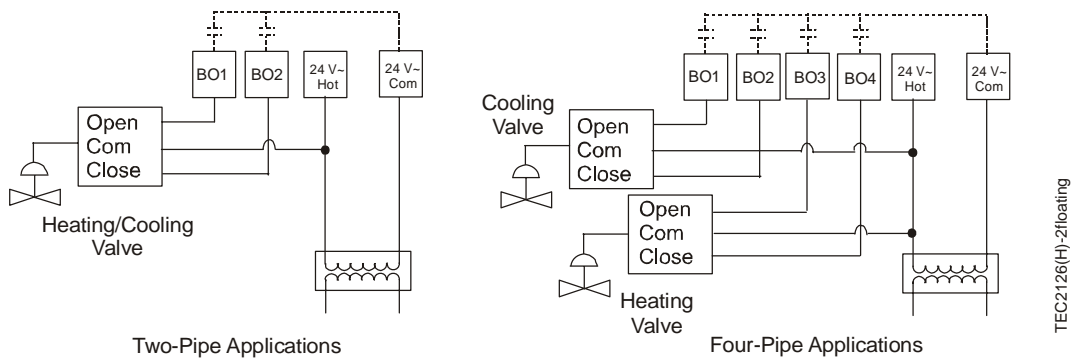

Figure 8: Wiring TEC2126(H)-2 Thermostats for Floating Control

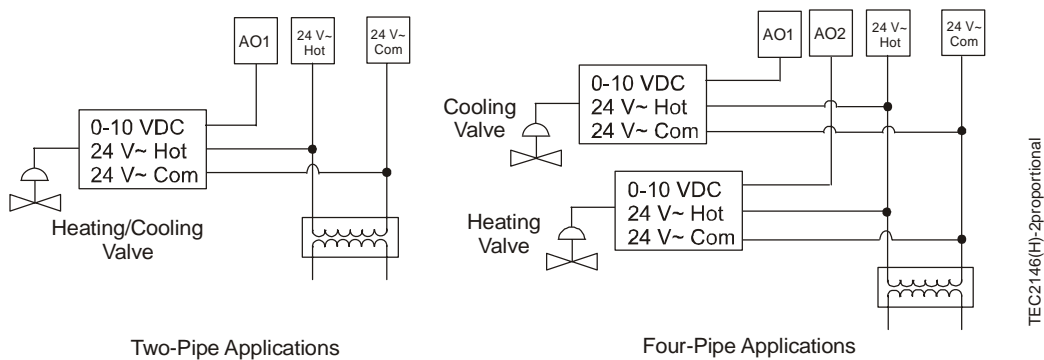

Figure 9: Wiring TEC2146(H)-2 Thermostats for Proportional Control

Table 2: N2 Bus Objects (Part 1 of 2)

Point Name	Thermostat Point (Type/Address)	N2 Bus Object Type	Model Point Type	Range
Room Temp ¹	ADI-1	N2 AI	CSAD	-40.0°F/-40.0°C to 122.0°F/50.0°C
Heating SP ^{1, 2} (Occupied Heating SP)	ADI-3	N2 AO	CSAD	40.0°F/4.5°C to 90.0°F/32.0°C
Cooling SP ^{1, 2} (Occupied Cooling SP)	ADI-4	N2 AO	CSAD	54.0°F/12.0°C to 100.0°F/38.0°C
Setback Heating SP ^{1, 2} (Unoccupied Heating SP)	ADI-5	N2 AO	CSAD	40.0°F/4.5°C to 90.0°F/32.0°C
Setback Cooling SP ^{1, 2} (Unoccupied Cooling SP)	ADI-6	N2 AO	CSAD	54.0°F/12.0°C to 100.0°F/38.0°C
PI Heating Demand	ADI-7	N2 AI	CSAD	0 to 100%
PI Cooling Demand	ADI-8	N2 AI	CSAD	0 to 100%
Fan ¹	BD-1	N2 MSO ³	CSMS	0 = Auto 1 = On 2 = Low 3 = Med 4 = High
System Mode ¹	BD-2	N2 MSO ³	CSMS	0 = Off 1 = Cool 2 = Heat 3 = Auto
Occupancy ¹	BD-3	N2 BO	CSBD	0 = Unoccupied 1 = Occupied
Sequence of Operation ^{1, 4}	BD-4	N2 MSO ³	CSMS	0 = Cooling 1 = Heating 2 = Cooling with Reheat 3 = Heating with Reheat 4 = Heating/Cooling 4-Pipe 5 = Heating/Cooling 4-Pipe with Reheat
Aux Output	BD-5	N2 BI	CSBD	0 = Off 1 = On
Low Fan Output	BD-6	N2 BI	CSBD	0 = Off 1 = On
Med Fan Output	BD-7	N2 BI	CSBD	0 = Off 1 = On
High Fan Output	BD-8	N2 BI	CSBD	0 = Off 1 = On

Table 2: N2 Bus Objects (Part 2 of 2)

Point Name	Thermostat Point (Type/Address)	N2 Bus Object Type	Model Point Type	Range
Temp Units ^{1, 5}	BD-9	N2 BO	CSBD	0 = °C 1 = °F
Status of Thermostat Occupancy Override	BD-10	N2 BI	CSBD	0 = No Override 1 = Override
B11 ^{6, 7}	BI-1	N2 BI	CSBI	0 = Off 1 = On
B12 ^{6, 7}	BI-2	N2 BI	CSBI	0 = Off 1 = On

1. Commandable.
2. The Heating SP and Cooling SP cannot be overridden simultaneously (this also applies to the Unoccupied Heating SP and Unoccupied Cooling SP). The overridden setpoint must be released prior to overriding the other setpoint. Additionally, if one setpoint is overridden, the other setpoint may be automatically adjusted by the TEC21x6(H)-2 Series Thermostat to maintain the minimum deadband between the two setpoints.
3. The Multiple Command Object (MCO) is used to command multiple Multistate Object (MSO) outputs. If downloading points via a PRN file, it is necessary to change the Object Type to MSO in order to use multiple outputs.
4. The Sequence of Operation Range 4 and Range 5 should only be for 4-pipe systems.
5. On the supervisory controller, map Temp Units BD-9 as a Binary Output (BO) object with Auto Restore and Local Control set.
6. Can be Change-of-State (COS) alarm to the supervisory controller to initiate dial-out.
7. The state of B11 and B12 is communicated over the N2 network even if the digital inputs are configured as **None** through the local interface at the thermostat.

Connecting the N2 Bus

To connect the N2 Bus:

1. Set the N2 address of the TEC21x6(H)-2 Series Thermostat per the engineering drawings prior to wiring the thermostat. (See the *Com addr* parameter in Table 3 to set the N2 address for the thermostat.) Also test for N2 voltage, polarity, and isolation prior to wiring the thermostat.
2. Observe the polarity when connecting the N2 Bus wires to the thermostat.
3. After the N2 Bus wires are connected to the first thermostat, continue in a daisy-chained fashion to the next thermostat.

Note: The thermostat N2 Bus is self-terminating. The N2 Bus wiring must be twisted-pair lines. Do not run the N2 Bus wiring in the same conduit as line voltage wiring (30 VAC or above) or other wiring that switches power to highly inductive loads (such as contactors, coils, motors, or generators).

For more N2 Bus overview information, refer to the *N2 Communications Bus Technical Bulletin (LIT-636018)* and the *ASC and N2 Bus Networking and Troubleshooting Guide (LIT-6363003)*.

N2 Device Mapping

Define the TEC21x6(H)-2 Series Thermostat as a Vendor Device (VND) when adding the thermostat to a supervisory controller.

The Thermostat Point (Type/Address) is the fixed-point definition inside the thermostat. The most recent N2 command received by any of the Object Types listed in Table 2 controls the thermostat.

Only one of the setpoints (either Heating SP or Cooling SP) can be overridden at a time. Overrides take priority over any local adjustment or command in the thermostat.

If a setpoint is overridden, the thermostat adjusts the other setpoint, if necessary, to maintain the minimum deadband between the two setpoints. The setpoints can be spread further apart, but can never be adjusted closer than 2F°/1C° apart.

If a supervisory controller commands an override of an analog or binary object, all local changes attempted through the thermostat keypad for that object are ignored until the override is released. For example, if the supervisory controller sends an override command to turn System Mode Off, and then the user selects System Mode On at the thermostat keypad, the thermostat keeps the System Mode Off.

When an override is released, the object may once again be changed via the thermostat keypad, but the thermostat does not retain any data entered at the thermostat keypad during the override.

All overrides are released automatically after 10 minutes of no communications (for example, if the network cable is removed from the thermostat causing a loss of network communications).

Metasys System Person-Machine Interface (PMI)

Do not direct-map any points; instead, run control of these points through the Control System (CS) object. The supervisory controller Model Point Type is the definition inside the model file. Use a CS object to retrieve the data.

Setup and Adjustments

Thermostat Operation Overview

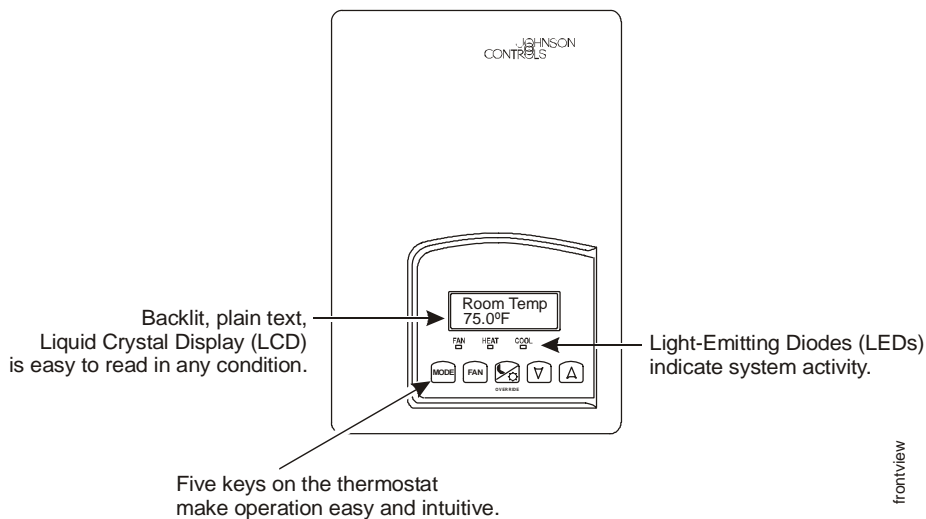

Figure 10: Front Cover of Thermostat

Thermostat User Interface Keys

The TEC21x6(H)-2 Series Thermostat user interface consists of five keys on the front cover (as illustrated in Figure 10). The function of each key is as follows:

- **MODE** key toggles among the system modes available, as defined by selecting the appropriate operation sequence in the Installer Configuration Menu (for example Off, Heat, Cool, Auto).
- **FAN** key toggles among the fan modes available, as defined by selecting the appropriate fan menu options defined in the Installer Configuration Menu (for example Low, Med, High, Auto).
- **VERRIDE** key (commercial models) activates the override function and allows access to the Installer Configuration Menu. See the *Configuring the TEC21x6(H)-2 Series Thermostat* section.

- Overrides the unoccupied mode to occupied at the local user interface for the specified TOccTime. (TOccTime is defined by selecting the appropriate time period in the Installer Configuration Menu.)

Note: If one of the binary inputs is configured to operate as a remote override contact, this **VERRIDE** key is disabled.

- **°C/°F** key (hospitality models) changes the temperature scale to either Celsius or Fahrenheit and allows access to the Installer Configuration Menu. See the *Configuring the TEC21x6(H)-2 Series Thermostat* section.
- **UP/DOWN** arrow keys change the configuration parameters and activate a setpoint adjustment.

Backlit LCD

The TEC21x6(H)-2 Series Thermostats include a 2-line, 8-character backlit display. Low-level backlighting is present during normal operation, and it brightens when any user interface key is pressed. The backlight returns to low level when the thermostat is left unattended for 45 seconds.

LEDs

Three LEDs are included to indicate the fan status, call for heat, or call for cooling:

- The **FAN** LED is on when the fan is on.
- The **HEAT** LED is on when heating or reheat is on.
- The **COOL** LED is on when cooling is on.

Status Display Menu

The Status Display Menu is displayed during normal thermostat operation. This menu continuously scrolls through the following parameters:

- Room Temperature
- System Mode
- Schedule Status – Occupied/Unoccupied/Override
- Applicable Alarms – The backlight lights up as an alarm condition is displayed.

Note: An option is available within the Installer Configuration Menu to lock out the scrolling display and show only the Room Temperature parameter.

Configuring the TEC21x6(H)-2 Series Thermostat

The TEC21x6(H)-2 Series Thermostat comes from the factory with default settings for all configurable parameters. The default settings are shown in Table 3. To reconfigure the parameters via the thermostat, follow the steps in this section.

To access the Installer Configuration Menu, press and hold the center key for approximately 8 seconds. Once the Installer Configuration Menu begins, release and press the center key to scroll through the parameters listed in Table 3. When the desired parameter is displayed, use the **UP/DOWN** arrow keys to choose the desired selection option. Then press and release the center key to continue scrolling through the parameters.

Note: Pressing the **FAN** key during configuration restarts the list of displayed parameters at the first parameter listed in Table 3.

When the thermostat is in the Installer Configuration Menu and left unattended for approximately 8 seconds, the thermostat reverts to the Status Display Menu.

Configuring Inputs BI1, BI2, and UI3

When BI1 and BI2 are configured for an alarm condition, an alarm condition is displayed locally when the input is closed. An alarm message is included on the scrolling Status Display Menu and when the message is displayed, the backlight momentarily lights up.

The UI3 input provides changeover of hot/cold water switching, or supply air temperature monitoring at the thermostat.

Each input can be configured to the Selection Options included in Table 3.

Table 3: Installer Configuration Menu (Part 1 of 5)

Parameter Appearing on Display	Description and Default	Selection Options
Com addr	N2 address at the thermostat; coincides with the address assigned at the supervisory controller. Pressing the UP/DOWN arrow keys simultaneously displays the N2 address that is assigned. Default: 4	Range: 0 to 253
BI1	Configuration of Binary Input 1. Default: None	<p>(None): No function is associated with an input.</p> <p>(Rem NSB): Remote Night Setback (NSB) via a time clock input, an occupancy sensor, or from a voltage-free contact. Contact open = Occupied; contact closed = Unoccupied</p> <p>(MotionNO*): Temporary occupancy request via a motion detector input. Contact open = Unoccupied. When the contact closes, the thermostat goes into the occupied mode for a specified TOccTime. Once the TOccTime begins, the thermostat remains in the occupied mode if the contact is open, until the TOccTime expires.</p> <p>(MotionNC*): Temporary occupancy request via a motion detector input. Contact closed = Unoccupied. When the contact opens, the thermostat goes into the occupied mode for a specified TOccTime. Once the TOccTime begins, the thermostat remains in the occupied mode if the contact is closed, until the TOccTime expires.</p> <p>(Window): Cancels the thermostat heating or cooling action when a window is open. The fan operation is not affected. A Window alarm is displayed indicating that the window needs to be closed to resume heating or cooling.</p> <p>* These settings disable any local override function.</p>
BI2	Configuration of Binary Input 2. Default: None	<p>(None): No function is associated with an input.</p> <p>(Door Dry): Door contact only has an effect if BI1 is set to MotionNO or MotionNC. (See the <i>BI1</i> parameter earlier in this table.) The occupancy is now dictated via BI1 and BI2. Any motion detected sets the zone to Occupied status. The thermostat remains in the occupied mode until a DoorOpen is detected, at which point the thermostat goes to the unoccupied mode. If the door stays open more than the specified door time, the thermostat will remain unoccupied. (See the <i>Door Time</i> parameter later in this table.)</p> <p>(RemOVR): Temporary occupancy request via a remote input. This override function is controlled by a manual remote occupancy override. When enabled, this condition disables the override capability of the thermostat.</p> <p>(Filter): A Filter alarm is displayed. This alarm can be connected to a differential pressure switch that monitors a filter.</p> <p>(Service): A Service alarm is displayed. This alarm can be connected to a float switch that is used for drip pan alarming, or it can be tied into the air conditioning unit control card, which provides an alarm should there be a malfunction.</p>

Table 3: Installer Configuration Menu (Part 2 of 5)

Parameter Appearing on Display	Description and Default	Selection Options				
UI3	Configuration of Universal Input 3. Default: None	<p>(None): No function is associated with an input.</p> <p>(COC/NH*): Change Over Contact/Normally Heat: A dry contact input is used to signal seasonal hot/cold water changeover. The contact closes when cold water is present. Valid for two-pipe systems only.</p> <p>(COC/NC*): Change Over Contact/Normally Cool: A dry contact input is used to signal seasonal hot/cold water changeover. The contact closes when hot water is present. Valid for two-pipe systems only.</p> <p>(COS*): Change Over analog Sensor: Used for hot/cold water changeover switching. Valid for two-pipe systems only.</p> <p>(SS**): Supply air Sensor monitoring: Used for local thermostat monitoring of the supply air temperature only; there is no supply air sensor monitoring at the supervisory controller.</p> <p>* The status of COC and COS cannot be monitored at the supervisory controller. These features may override the SeqOpera parameter. (See the SeqOpera parameter later in this table.)</p> <p>** The status of SS cannot be monitored at the supervisory controller.</p>				
MenuScro	Gives the option of having the display continuously scroll the parameters. Default: on	<p>(on): The scroll is active.</p> <p>(off): The scroll is inactive.</p>				
AutoMode	Enables the Auto function (if Option 2 is chosen in the SeqOpera parameter) to be visible within the MODE key menu. (The MODE key is the key at the far left of the thermostat cover.) Default: off	<p>(on): The Auto function is active (Off-Auto-Heat-Cool). Provides automatic changeover between heating and cooling.</p> <p>(off): The auto function is inactive (Off-Heat-Cool).</p>				
C or F	Provides temperature scale options for display. Default: °F	<p>(°F): Fahrenheit scale</p> <p>(°C): Celsius scale</p>				
Lockout	Selectable Lockout Levels for limiting end user keypad interaction. Default: 0	Lockout Level	Function			
			Mode Setting	Fan Setting	Local Override	Occupied Temperature Setpoints
			(0)	Access	Access	Access
			(1)	Access	No Access	Access
			(2)	No Access	Access	Access
			(3)	No Access	No Access	Access
		(4)	No Access	Access	No Access	
		(5)	No Access	No Access	No Access	
Pipe No	Selectable number of pipes in the system. Default: 4.0 Pipes	<p>(2.0 Pipes): Limits the number of sequences of operation available from 0 to 3, and enables heat/cool operation from the same output.</p> <p>(4.0 Pipes): Allows access to all sequences of operation from 0 to 5, and enables heat/cool operation from different outputs.</p>				

Table 3: Installer Configuration Menu (Part 3 of 5)

Parameter Appearing on Display	Description and Default	Selection Options	
CntrlTyp	Defines the control output for the type of valves used in the installation (TEC2126-2 and TEC2126H-2 models). Default: On/Off	(On/Off): For Normally Open (N.O.) or Normally Closed (N.C.) 24 VAC two-position valves. (Floating): For proportional three-wire control of 24 VAC floating valves.	
SeqOpera	Determines the sequence of operation. Default: 1	(0): Cooling only (Off-Cool) (1): Heating only (Off-Heat) (2): Cooling with reheat (Off-Auto*-Heat-Cool) (3): Heating with reheat (Off-Heat) (4**): Cooling/Heating (Off-Auto*-Heat-Cool) (5**): Cooling/Heating with reheat (Off-Auto*-Heat-Cool) * Auto can be disabled with the AutoMode parameter. ** Four-pipe systems only	
Fan Menu	Sets the Fan Mode options. Default: 4	(0): Low-Med-High: Three-speed configuration using three fan relays (L-M-H) (1): Low-High: Two-speed configuration using two fan relays (L-H) (2): Low-Med-High-Auto: Three-speed configuration with Auto Fan speed mode using two fan relays (L-H) (3): Low-High-Auto: Two-speed configuration with Auto Fan speed mode using two fan relays (L-H) (4): On-Auto: One-speed configuration, (H) Auto is for Fan on demand and On is for Fan on all the time	
Unocc HT	Sets the Unoccupied Heating setpoint value. Default: 62.0°F/16.5°C	Range: 40.0°F/4.5°C to 90.0°F/32.0°C	Note: When adjusting the temperature, press the UP/DOWN arrow keys to change the temperature in 0.5F°/0.5C° increments; press and hold the UP/DOWN arrow keys to change the temperature in 5.0F°/5.0C° increments.
Unocc CL	Sets the Unoccupied Cooling setpoint value. Default: 80.0°F/26.5°C	Range: 54.0°F/12.0°C to 100.0°F/37.5°C	
Heat max	Sets the Occupied and Unoccupied maximum Heating setpoint values. Default: 90.0°F/32.0°C	Range: 40.0°F/4.5°C to 90.0°F/32.0°C	
Cool min	Sets the Occupied and Unoccupied minimum Cooling setpoint values. Default: 54.0°F/12.0°C	Range: 54.0°F/12.0°C to 100.0°F/37.5°C	
Set type	Provides the option of temporarily changing the heating or cooling setpoint by pressing the UP/DOWN arrow keys. Default: permnent	(temporar): Local changes to the heating or cooling setpoints are temporary, and remain effective for the specified TOccTime. (permnent): Local changes to the heating or cooling setpoints are permanently stored in the thermostat memory.	
TOccTime	Sets the duration of the Temporary Occupancy Time when the heating or cooling setpoints in the Occupied mode are established by: <ul style="list-style-type: none"> an Override Function enabled in the Main User Menu (when the thermostat is in the Unoccupied mode) a temporary heating or cooling setpoint Default: 2.0 hrs	Range: 0.0 to 24.0 hrs in 1-hour increments	

Table 3: Installer Configuration Menu (Part 4 of 5)

Parameter Appearing on Display	Description and Default	Selection Options			
DoorTime	Engages the Unoccupied mode if the door stays open minimally for the time specified. Default: 2.0 min	Range: 1.0 to 10.0 min			
Deadband	Sets the minimum deadband between the heating and cooling setpoints. Default: 2.0F°/1.0C°	Range: 2.0F°/1.0C° to 5.0F°/2.5C° (adjustable in 1.0F°/0.5C° increments)			
Cal RS	Sets the desired room air sensor calibration (offset). The offset can be added to or subtracted from the actual displayed room temperature. Default: 0.0F°/0.0C°	Range: -5.0F°/-2.5C° to 5.0F°/2.5C° (adjustable in 1.0F°/0.5C° increments)			
Aux cont	Determines the auxiliary contact function and configuration. Default: 0	(0)	Not used, or not used for reheat	If the sequence is set to reheat (2, 3, or 5), ignore this parameter.	
		(1)	Auxiliary N.O.	Occupied = contact closed Unoccupied = contact open	The output aligns with occupancy.
		(2)	Auxiliary N.C.	Occupied = contact open Unoccupied = contact closed	
		(3)	Auxiliary N.O.	Occupied and fan On = contact closed Unoccupied and fan On or Off = contact open	The output aligns with occupancy and the fan on command.
		(4)	Auxiliary N.C.	Occupied and fan On = contact open Unoccupied and fan On or Off = contact closed	
		(5)	This selection option is not used.		
FL time	Sets the maximum actuator stroke timing (TEC2126-2 and TEC2126H-2 models). Default: 1.5 min	Range: 0.5 to 9.0 min (adjustable in 0.5 minute increments)			
cph	Sets the maximum number of cycles per hour (TEC2116-2 and TEC2116H-2 models). Default: 4	Range: 3 to 8 cycles per hour			
DA/RA	Choice of direct or reverse acting analog output signal. Default: DA	(DA): Direct acting, 0 to 100% = 0 to 10 VDC (RA): Reverse acting, 0 to 100% = 10 to 0 VDC			

Table 3: Installer Configuration Menu (Part 5 of 5)

Parameter Appearing on Display	Description and Default	Selection Options
Reheat	Sets the duty cycle time for reheat output (if Option 2, 3, or 5 is chosen in the SeqOpera parameter). Default: 0	(0) : 15 minutes (four cycles per hour), for various equipment with mechanical relays or contactors controlling mechanical reheat systems. (1) : 10 seconds (six cycles per minute), for various equipment with solid-state relays that withstand short duty cycles such as electric heat.
SS dis	Displays the supply or changeover temperature when UI3 is configured as an analog input (SS or COS). Used as a diagnostic/service help, to troubleshoot and diagnose sensor operation. Default: -40°F/-40°C	Not applicable

Accessories

All the optional accessories in Table 4 include mounting hardware; contact the nearest Johnson Controls® representative to order any of these parts.

Note: Review the technical specifications of the optional accessories prior to their use in an application.

Table 4: Accessories (Order Separately)

Code Number	Description
SEN-600-1	Remote Indoor Air Temperature Sensor
SEN-600-3	Duct Mount Air Temperature Sensor
SEN-600-4	Remote Indoor Air Temperature Sensor with Occupancy Override and LED

Repairs and Replacements

If the TEC21x6(H)-2 Series Thermostat fails to operate within its specifications, see Table 5 for troubleshooting details and Table 6 for alarm messaging. For a replacement thermostat, contact the nearest Johnson Controls representative.

Table 5: Troubleshooting Details

Error/Trouble Condition	Probable Cause	Solution
Thermostat Cycles Online and Offline	Two or more controllers have the same address.	Change each duplicate address to a unique number.
	There are Y or T taps on the N2 Bus, or the repeater has lost power or is wired incorrectly.	Refer to the <i>N2 Communications Bus Technical Bulletin (LIT-636018)</i> .
Thermostat Does Not Come Online	Two or more controllers have the same address.	Change each duplicate address to a unique number.
	The N2 Bus contains too many devices.	Do not exceed the maximum number of devices allowed on the N2 Bus per supervisory controller limitations.
	The thermostat does not have power.	Apply power to the thermostat.
	The N2 cable runs are broken.	Locate the break and correct the wiring.
	The thermostat device type is incorrect.	Change the thermostat device type to VND.
N2 Bus is Offline	The wiring on the N2 Bus is broken.	Repair the wiring.
	No point mapping has been entered.	Define the BAS dataset.

Table 6: Alarm Messages

Display	Function
Service	Indicates that there is a service alarm in accordance with the programmable Binary Input (BI2).
Filter	Indicates that the filter(s) is dirty in accordance with the programmable Binary Input (BI2).
Window	Indicates that an outside window or door is open and has cancelled the thermostat heating or cooling action in accordance with the programmable Binary Input (BI1).

Technical Specifications

TEC21x6(H)-2 Series N2 Networked Thermostats with Two Outputs and Three Speeds of Fan Control

Power Requirements		20 to 30 VAC, 50/60 Hz, 2 VA (Terminals 4 and 5) at 24 VAC Nominal, Class 2 or Safety Extra-Low Voltage (SELV)
Relay/Triac Contact Rating	On/Off and Floating Control	30 VAC, 1.0 A Maximum, 3.0 A In-Rush
Analog Output Rating	Proportional Control	0 to 10 VDC into 2k ohm Resistance (Minimum)
Fan Relay Output Rating		30 VAC, 1.0 A Maximum, 3.0 A In-Rush
Auxiliary Output Rating	Triac Output	30 VAC, 1.0 A Maximum, 3.0 A In-Rush
Digital Inputs		Voltage-Free Contacts Across Terminal Scom to Terminals BI1, BI2, or UI3
Wire Size		18 AWG Maximum, 22 AWG Recommended
Thermostat Measurement Range		-40.0°F/-40.0°C to 122.0°F/50.0°C
Sensor Type		Local 10k ohm Negative Temperature Coefficient (NTC) Thermistor
Resolution		±0.2F°/±0.1C°
Control Accuracy		±0.9F°/±0.5C° at 70.0°F/21.0°C Typical Calibrated
Control Range	Heating	40.0°F/4.5°C to 90.0°F/32.0°C in 0.5° Increments
	Cooling	54.0°F/12.0°C to 100.0°F/38.0°C in 0.5° Increments
Minimum Deadband		2F°/1C° between Heating and Cooling
Ambient Conditions	Operating	32 to 122°F (0 to 50°C); 95% RH Maximum, Noncondensing
	Storage	-22 to 122°F (-30 to 50°C); 95% RH Maximum, Noncondensing
Compliance	United States	UL Listed, File E27734, CCN XAPX, Under UL 873, Temperature Indicating and Regulating Equipment
		FCC Compliant to CFR 47, Part 15, Subpart B, Class A
	Canada	UL Listed, File E27734, CCN XAPX7, Under CSA C22.2 No. 24, Temperature Indicating and Regulating Equipment
		Industry Canada, ICES-003
	European Union	CE Mark, EMC Directive 89/336/EEC (Pending)
Australia and New Zealand	C-Tick Mark, Australia/NZ Emissions Compliant (Pending)	
Shipping Weight		0.75 lb (0.34 kg)

The performance specifications are nominal and conform to acceptable industry standards. For application at conditions beyond these specifications, consult the local Johnson Controls office. Johnson Controls, Inc. shall not be liable for damages resulting from misapplication or misuse of its products.



Controls Group
507 E. Michigan Street
Milwaukee, WI 53202

© 2005 Johnson Controls, Inc.