

# TEC21x6(H)-2 Series N2 Networked Thermostats with Two Outputs, Dehumidification Capability, and Three Speeds of Fan Control

## Product Bulletin

Code No. LIT-12011079  
 Issued July 20, 2006  
 Supersedes October 25, 2005

The TEC21x6(H)-2 Series Thermostats are N2 networked devices that provide control of two- or four-pipe fan coils, cabinet unit heaters, or other equipment using on/off, floating, or proportional 0 to 10 VDC control input, three speeds of fan control, and dehumidification capability. The technologically advanced TEC21x6(H)-2 Series Thermostats feature a Building Automation System (BAS) N2 Bus communication capability that enables remote monitoring and programmability for efficient space temperature control. Specific models are available to accommodate commercial and hospitality applications.

The TEC21x6(H)-2 Series Thermostats feature an intuitive user interface with backlit display that makes setup and operation quick and easy. The thermostats also employ a unique, Proportional-Integral (PI) time-proportioning algorithm that virtually eliminates temperature offset associated with traditional, differential-based thermostats.



**Figure 1: TEC21x6-2 Series N2 Networked Thermostat with Two Outputs, Dehumidification Capability, and Three Speeds of Fan Control**

**Table 1: Features and Benefits**

Feature	Benefit
<b>BAS N2 Open Communication</b>	Provides compatibility with a proven communication network; N2 Bus is widely accepted by Heating, Ventilating, and Air Conditioning (HVAC) control suppliers
<b>Integral Humidity Sensing Capability (Dehumidification Models)</b>	Increases occupancy comfort by providing dehumidification
<b>Backlit Liquid Crystal Display (LCD)</b>	Offers real-time control status of the environment in easy-to-read, English plain text messages with constant backlight that brightens during user interaction
<b>On/Off, Floating, or Proportional 0 to 10 VDC Control</b>	Offers additional application flexibility by providing more advanced control signals
<b>Three Speeds of Fan Control</b>	Provides easy <b>FAN</b> speed selection via interface key, to meet the application requirements
<b>Override Interface Key (Commercial Models)</b>	Allows easy access for temporarily overriding the unoccupied mode
<b>Temperature Scale Selector (Hospitality Models)</b>	Offers guests the ability to select a Fahrenheit (°F) or Celsius (°C) temperature scale display
<b>Simplified Setpoint Adjustment</b>	Enables the user to change the setpoint by simply pressing the <b>UP/DOWN</b> arrow keys
<b>Two Configurable Binary Inputs</b>	Provide additional inputs for advanced functions such as remote night setback, service or filter alarms, motion detector, and window status
<b>Over 20 Configurable Parameters</b>	Enable the thermostat to adapt to any application, allowing installer parameter access without opening the thermostat cover
<b>Discharge Air Sensor</b>	Monitors unit efficiency

## Product Overview

The TEC21x6(H)-2 Series Thermostats are specifically designed for networked control of common two- or four-pipe heating and cooling equipment using on/off, floating, or proportional 0 to 10 VDC control. In addition to superior temperature control and application flexibility, the TEC21x6(H)-2 Series features BAS N2 Bus communication capability, allowing the user to view operation or make adjustments from a remote workstation. Plain text menus, backlit display, and five interface keys make setup and operation quick and easy.

**IMPORTANT:** The TEC21x6(H)-2 Series Thermostats are intended to provide an input to equipment under normal operating conditions. Where failure or malfunction of the thermostat could lead to personal injury or property damage to the controlled equipment or other property, additional precautions must be designed into the control system. Incorporate and maintain other devices such as supervisory or alarm systems or safety or limit controls intended to warn of, or protect against, failure or malfunction of the thermostat.

## Additional Features

The TEC21x6(H)-2 Series Thermostats offer many other features, including:

- **Adjustable Heating/Cooling Deadband**  
Adjusts the minimum heating/cooling deadband from 2.0F°/1.0C° to 4.0F°/2.0C°.
- **Remote Indoor Sensing**  
Accommodates remote indoor sensors. Up to three indoor sensors can be averaged.

- **Five Easy-to-Use Interface Keys**  
Allow for easy commissioning of the thermostat, and eliminates the need for DIP switches.
- **Six Levels of Keypad Lockout**  
Provide six levels of keypad lockout that can be set up through the Installer Configuration Menu.
- **Accessible Configuration Parameters**  
Allow local access to all configurable parameters while limiting unwanted parameter tampering once the thermostat is set up.
- **Three Light-Emitting Diodes (LEDs)**  
Provide fan, heating, and cooling status at a glance.
- **Adjustable Temporary Occupancy Time**  
Adjusts the temporary occupancy time from 0 to 24 hours.
- **Auxiliary Contact**  
Provides 24 VAC control for reheat, lighting, and other auxiliary functions.
- **Adjustable Heating/Cooling Cycles per Hour (On/Off Control)**  
Configurable for the maximum number of heating and cooling cycles (4 to 8 cycles maximum) in a 1-hour period, balancing temperature control and equipment cycling.
- **Nonvolatile Electrically Erasable Programmable Read-Only Memory (EEPROM)**  
Prevents loss of adjusted parameters during a power failure.
- **Remote Access**  
Allows the user to read/write and access the parameters of the thermostat via a supervisory controller.

**Table 2: Thermostat Models**

Code Number	Control Outputs	Fan Control	Integral Humidity Sensor	Application
TEC2116-2	Two On/Off	Three Speeds	No	Commercial Market
TEC2116H-2	Two On/Off	Three Speeds	No	Hospitality Market
TEC2126-2	Two On/Off or Floating	Three Speeds	No	Commercial Market
TEC2126H-2	Two On/Off or Floating	Three Speeds	No	Hospitality Market
TEC2136-2	Two On/Off or Floating	Three Speeds	Yes	Commercial Market
TEC2136H-2	Two On/Off or Floating	Three Speeds	Yes	Hospitality Market
TEC2146-2	Two Proportional 0 to 10 VDC	Three Speeds	No	Commercial Market
TEC2146H-2	Two Proportional 0 to 10 VDC	Three Speeds	No	Hospitality Market
TEC2156-2	Two Proportional 0 to 10 VDC	Three Speeds	Yes	Commercial Market
TEC2156H-2	Two Proportional 0 to 10 VDC	Three Speeds	Yes	Hospitality Market

**Table 3: Accessories (Order Separately)**

Code Number	Description
SEN-600-1	Remote Indoor Air Temperature Sensor
TE-6361P-1	Duct Mount Air Temperature Sensor
SEN-600-4	Remote Indoor Air Temperature Sensor with Occupancy Override and LED
TE-636S-1	Strap-On Temperature Sensor

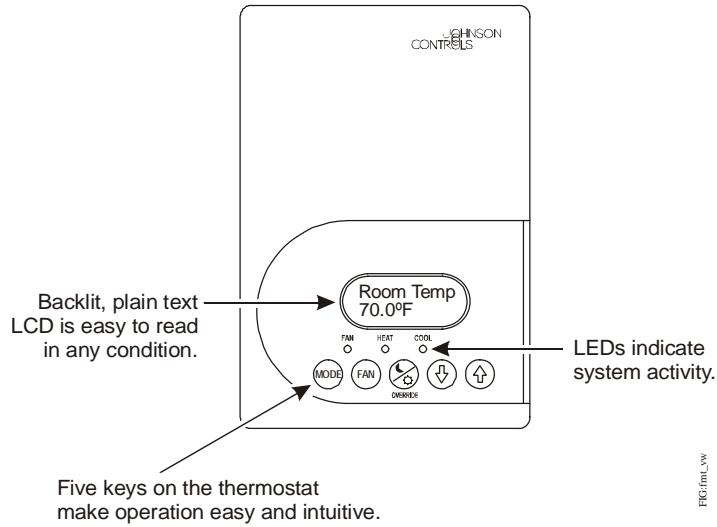

**Figure 2: Front Cover of Thermostat**

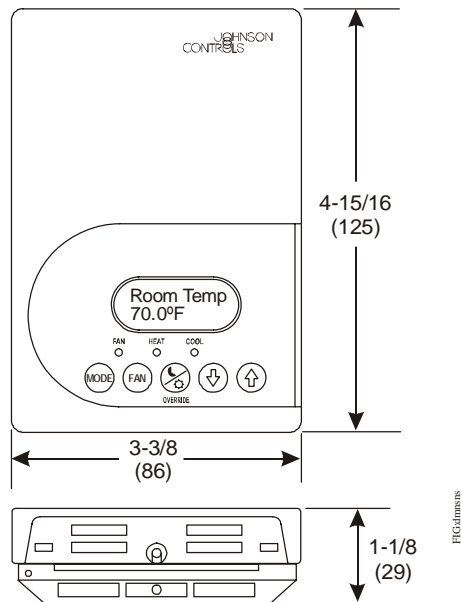

**Figure 3: Thermostat Dimensions, in. (mm)**

## Thermostat User Interface Keys

The TEC21x6(H)-2 Series Thermostats user interface consists of five keys on the front cover (as illustrated in Figure 2). The function of each key is as follows:

- **MODE** key toggles among the system modes available, as defined by selecting the appropriate operation sequence in the Installer Configuration Menu (for example Off, Heat, Cool, Auto).
- **FAN** key toggles among the fan modes available, as defined by selecting the appropriate fan menu options defined in the Installer Configuration Menu (for example Low, Med, High, Auto).
- **OVERRIDE** key (commercial models) overrides the unoccupied mode to occupied at the local user interface for the specified TOccTime. (TOccTime is defined by selecting the appropriate time period in the Installer Configuration Menu.) The **OVERRIDE** key also allows access to the Installer Configuration Menu. (See the *Installer Configuration Menu* section.)

**Note:** If one of the binary inputs is configured to operate as a remote override contact, this **OVERRIDE** key is disabled.

- **°C/°F** key (hospitality models) changes the temperature scale to either Celsius or Fahrenheit and allows access to the Installer Configuration Menu. (See the *Installer Configuration Menu* section.)
- **UP/DOWN** arrow keys change the configuration parameters and activate a setpoint adjustment.

## Backlit LCD

The TEC21x6(H)-2 Series Thermostats include a 2-line, 8-character backlit display. Low-level backlighting is present during normal operation, and it brightens when any user interface key is pressed. The backlight returns to low level when the thermostat is left unattended for 45 seconds.

## LEDs

Three LEDs are included to indicate the fan status, call for heat, or call for cooling:

- The **FAN** LED is on when the fan is on.
- The **HEAT** LED is on when heating or reheat is on.
- The **COOL** LED is on when cooling is on.

## Menu Overview

There are two menus available to view and configure the TEC21x6(H)-2 Series Thermostat:

- Status Display Menu
- Installer Configuration Menu

The following sections outline the functions and contents of each menu.

### **Status Display Menu**

The Status Display Menu is displayed during normal thermostat operation. This menu continuously scrolls through the following parameters:

- Room Temperature and Humidity (If Humidity Display is Enabled)
- System Mode
- Schedule Status (Occupied/Unoccupied/Override)
- Applicable Alarms (The backlight lights up as an alarm condition is displayed.)

**Note:** An option is available within the Installer Configuration Menu to lock out the scrolling display and show only the Room Temperature parameter.

### **Installer Configuration Menu**

The Installer Configuration Menu is used to set up the thermostat for an application-specific operation. To access the menu, press and hold the center key for approximately 8 seconds.

The Installer Configuration Menu includes the following parameters that are accessed by pressing the same center key:

- N2 Communication Address
- BI1 and BI2 Input Configuration
- Menu Scroll
- Auto Mode
- °F and °C Temperature Scales (Commercial Models)
- % RH Display (Dehumidification Models)
- Six Keypad Lockout Levels
- Pipe No.
- Sequence of Operation
- Fan Menu
- Dehumidification Network Lockout (Dehumidification Models)
- Dehumidification Setpoint (Dehumidification Models)
- Dehumidification Hysteresis (Dehumidification Models)

- Maximum Dehumidification Cooling Output (Dehumidification Models)
- Unoccupied Heating Setpoint/Unoccupied Cooling Setpoint
- Maximum Heating Setpoint/Minimum Cooling Setpoint
- Setpoint Type
- Temporary Occupancy Time
- Door Open Time
- Heating/Cooling Deadband
- Room Air Temperature Calibration
- Room Humidity Calibration (Dehumidification Models)
- Auxiliary Contact
- Floating Time (Floating Models)
- Cycles per Hour (On/Off Models)
- Direct/Reverse Acting
- Reheat Time
- UI3 Input Configuration to Locally Monitor Supply Air Temperature or Hot/Cold Water Changeover Switching

**Repair Information**

If the TEC21x6(H)-2 Series Thermostat fails to operate within its specifications, replace the unit. For a replacement thermostat, contact the nearest Johnson Controls® representative.

**Technical Specifications**

***TEC21x6(H)-2 Series N2 Networked Thermostats with Two Outputs, Dehumidification Capability, and Three Speeds of Fan Control (Part 1 of 2)***

<b>Power Requirements</b>		19 to 30 VAC, 50/60 Hz, 2 VA (Terminals 4 and 5) at 24 VAC Nominal, Class 2 or Safety Extra-Low Voltage (SELV)
<b>Relay/Triac Contact Rating</b>	<b>On/Off and Floating Control</b>	30 VAC, 1.0 A Maximum, 3.0 A In-Rush, Class 2 or SELV
<b>Analog Output Rating</b>	<b>Proportional Control</b>	0 to 10 VDC into 2k ohm Resistance (Minimum)
<b>Fan Relay Output Rating</b>		30 VAC, 1.0 A Maximum, 3.0 A In-Rush
<b>Auxiliary Output Rating</b>	<b>Triac Output</b>	30 VAC, 1.0 A Maximum, 3.0 A In-Rush
<b>Digital Inputs</b>		Voltage-Free Contacts Across Terminal Scm to Terminals BI1, BI2, or UI3
<b>Wire Size</b>		18 AWG (1.0 mm Diameter) Maximum, 22 AWG (0.6 mm Diameter) Recommended
<b>Thermostat Measurement Range</b>		-40.0°F/-40.0°C to 122.0°F/50.0°C
<b>Temperature Sensor Type</b>		Local 10k ohm Negative Temperature Coefficient (NTC) Thermistor
<b>Resolution</b>	<b>Temperature</b>	±0.2F°/±0.1C°
	<b>Humidity</b>	±5% RH from 20 to 80% RH at 50 to 90°F (10 to 32°C)
<b>Control Accuracy</b>		±0.9F°/±0.5C° at 70.0°F/21.0°C Typical Calibrated
<b>Control Range</b>	<b>Heating</b>	40.0°F/4.5°C to 90.0°F/32.0°C in 0.5° Increments
	<b>Cooling</b>	54.0°F/12.0°C to 100.0°F/38.0°C in 0.5° Increments
<b>Minimum Deadband</b>		2F°/1C° between Heating and Cooling
<b>Ambient Conditions</b>	<b>Operating</b>	32 to 122°F (0 to 50°C); 95% RH Maximum, Noncondensing
	<b>Storage</b>	-22 to 122°F (-30 to 50°C); 95% RH Maximum, Noncondensing

## TEC21x6(H)-2 Series N2 Networked Thermostats with Two Outputs, Dehumidification Capability, and Three Speeds of Fan Control (Part 2 of 2)

<b>Compliance</b>	<b>United States</b>	UL Listed, File E27734, CCN XAPX, Under UL 873, Temperature Indicating and Regulating Equipment
		FCC Compliant to CFR 47, Part 15, Subpart B, Class A
	<b>Canada</b>	UL Listed, File E27734, CCN XAPX7, Under CAN/CSA C22.2 No. 24, Temperature Indicating and Regulating Equipment
		Industry Canada, ICES-003
	<b>Europe</b>	CE Mark, EMC Directive 89/336/EEC
	<b>Australia and New Zealand</b>	C-Tick Mark, Australia/NZ Emissions Compliant
<b>Shipping Weight</b>		0.75 lb (0.34 kg)

The performance specifications are nominal and conform to acceptable industry standards. For application at conditions beyond these specifications, consult the local Johnson Controls office. Johnson Controls, Inc. shall not be liable for damages resulting from misapplication or misuse of its products.

### United States Emissions Compliance:

This equipment has been tested and found to comply with the limits for a Class A digital device pursuant to Part 15 of the FCC Rules. These limits are designed to provide reasonable protection against harmful interference when this equipment is operated in a commercial environment. This equipment generates, uses, and can radiate radio frequency energy and, if not installed and used in accordance with the instruction manual, may cause harmful interference to radio communications. Operation of this equipment in a residential area is likely to cause harmful interference, in which case the user will be required to correct the interference at his/her own expense.

### Canadian Emissions Compliance:

This Class (A) digital apparatus meets all requirements of the Canadian Interference-Causing Equipment Regulations.

Cet appareil numérique de la Classe (A) respecte toutes les exigences du Règlement sur le matériel brouiller du Canada.



### Controls Group

507 E. Michigan Street  
Milwaukee, WI 53202

© 2006 Johnson Controls, Inc.